



Digital Phone **Quick Reference Guide**

DS-5012L



COPYRIGHT

This manual is proprietary to SAMSUNG Electronics Co., Ltd. and is protected by copyright. No information contained herein may be copied, translated, transcribed or duplicated for any commercial purposes or disclosed to third parties in any form without the prior written consent of SAMSUNG Electronics Co., Ltd.

TRADEMARKS

OfficeServ™ is the trademark of SAMSUNG Electronics Co., Ltd.
Product names mentioned in this document may be trademarks and/or registered trademarks of their respective companies.

This manual may be changed for product improvement, standardization and other technical reasons without prior notice.

For further information on the updated manual or the content contained in the manual, contact your Authorised Samsung Reseller.

<http://www.samsungdocs.com>

Enterprise IP Solutions

OfficeServ Digital Phone **Quick Reference Guide**

DS-5012L

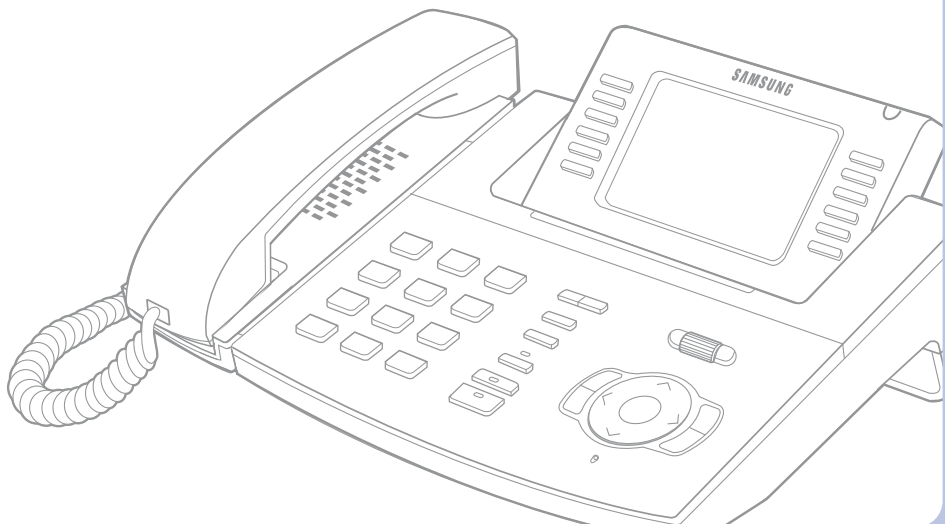

SAFETY CONCERNS

For product safety and correct operation, the following information must be given to the operator/user and shall be read before the installation and operation.

Conventions



WARNING

WARNING

Provides information or instructions that you should follow in order to avoid personal injury or fatality.



CAUTION

CAUTION

Provides information or instructions that you should follow in order to avoid a service failure or damage to your phone.



NOTE

Indicates additional information for reference.

Symbols



Caution

Indication of a general caution



Restriction

Indication of a prohibited action for the phone



Instruction

Indication for commanding a specifically required action



WARNING

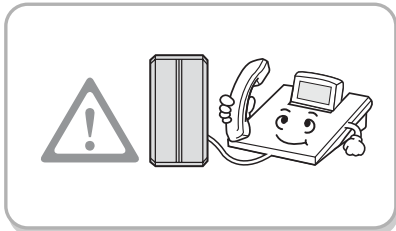

The DS-5012L digital phone is only for connection to SELV systems.



The handset receiver on the phone may retain metallic objects. Care should be taken when using the handset in the vicinity of small metal objects.



Avoid placing objects containing water such as vases, cups, cosmetics, and medicines near the phone.

Moisture in the phone may cause a fire and electric shocks.

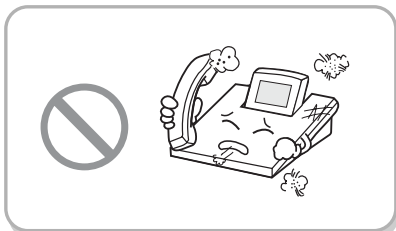

Do not place the phone in a dusty area or areas with extreme or volatile changes in temperature.

It may cause a fire or electric shocks.



Do not install the phone near a heater or flames (cigarette lighter, heating apparatus, etc.).

It may cause a fire or electric shocks.

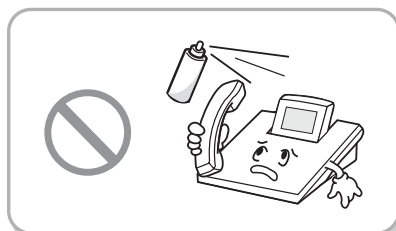

Do not use flammable solvent or materials near the phone. Do not store them near the phone.

It may cause a fire or electric shocks.

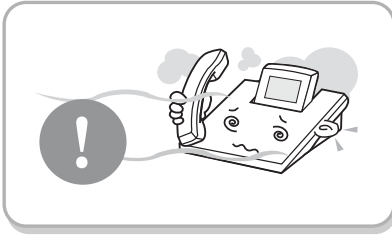

If the phone makes excessive noise, emits an odour, or smoke, immediately unplug the phone and call your Authorised Samsung Reseller.

CAUTION

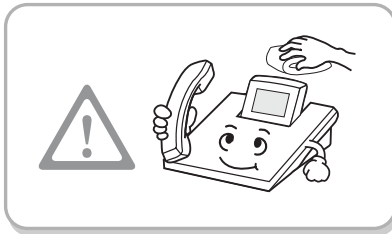

Use a soft dry cloth to clean the phone. Do not use any chemical solvents like wax, benzene, alcohol, thinner, aerosols, lubricant, or detergent.

The use of chemicals on the phone may cause fading/discoloring or damage to the parts.

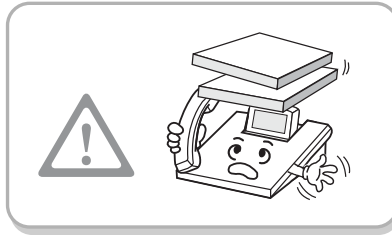

Do not place heavy things on the phone.

It may cause damage to some parts.

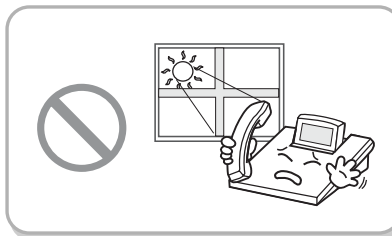

Do not install the phone on an unstable surface or in direct sunlight.

It may cause severe damage to the plastic case of the phone, and reduced the performance of your phone.

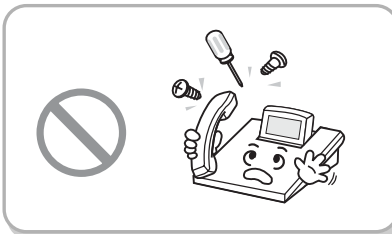

Do not separate, repair or remodel the phone arbitrarily.

If a repair is needed, please contact your Authorised Samsung Reseller.

TABLE OF CONTENTS

SAFETY CONCERNS

Conventions.....	2
Symbols.....	2
Warning	3
Caution	3

PREPARATION

Main Features.....	6
Front View of the Phone	9
Connecting Lines to the Phone.....	10

THINGS YOU SHOULD KNOW

Volume Adjustment.....	11
Entering Characters.....	13
Telephone Status Indicator	16
Button LED	16

USING THE FEATURES

Making a Call.....	17
Answering a Call.....	22
Features Used During a Call	24

APPLICATION MENUS

Navigation Buttons	29
Entering Application Menus	31

ANNEX

Troubleshooting	33
Product Specifications	35

PREPARATION

Main Features

Large LCD Screen

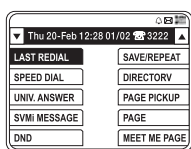

Displays various kinds of information, and you can simply press the related [Selection] button next to the feature/menu. This feature provides easy search and selection of menus and features.

Application menu

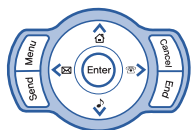

Allows you to easily check the phone functions(Phonebook, E-Diary, Message, Volume, Forward, Config., and My Phone) with an icon or menu on the LCD screen just like a mobile cellular phone. You can use the Application menu to search any long text displayed on the LCD panel.

Speed Dial

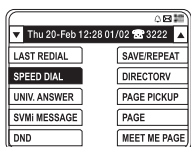

For further convenient use of your phone, you can program your frequently used phone numbers into the phone's Phone Book. For important numbers, you can press one dial button to make a call to the speed dial number.

Pickup



You can answer a call at another extension.

Automatic Redial/Retry



When your call is important but your party is busy on another call you can use automatic redial/retry function. The digital phone redials the called number automatically until your party is free to take your call.

Hold

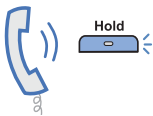

You can use the Hold function when you need something or another call is arrives. Use this button to temporarily hold the current call until you are ready to resume the call. You can even pickup the held call at another station.

Conference Calls



This button is used when multiple parties need to be connected simultaneously during a phone conversation. Up to five parties including you can be connected in a conference call.

Call Forwarding

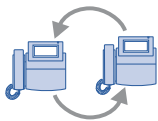

If you cannot answer an incoming call, the call can be forwarded to another extension(unconditionally, while you are busy on a call, or when you are away from your phone).

Do Not Disturb



When you do not want to be disturbed, the DND function can be set to block incoming calls and the phone will not ring. Your calls can be forwarded to another station when you cannot be disturbed.

Paging



If you have an urgent announcement to make, or you wish to locate a colleague, you can page through the speaker of other stations, or through optional external speakers.

Executive/Secretary



When the Executive/Secretary button is pressed once, the executive and his/her secretary can be connected.
The secretary can use this Executive/Secretary feature to receive an incoming call and then simply forward it to the executive.

Call ID



When there is an incoming call, the caller ID or name will be displayed on the LCD screen. You can see who is calling before answering the call and respond accordingly.

**NOTE**

If you have any questions or concerns regarding the features which are not introduced in this user guide, refer to the User Guide at e-manual site(<http://www.samsungdocs.com>).

Front View of the Phone

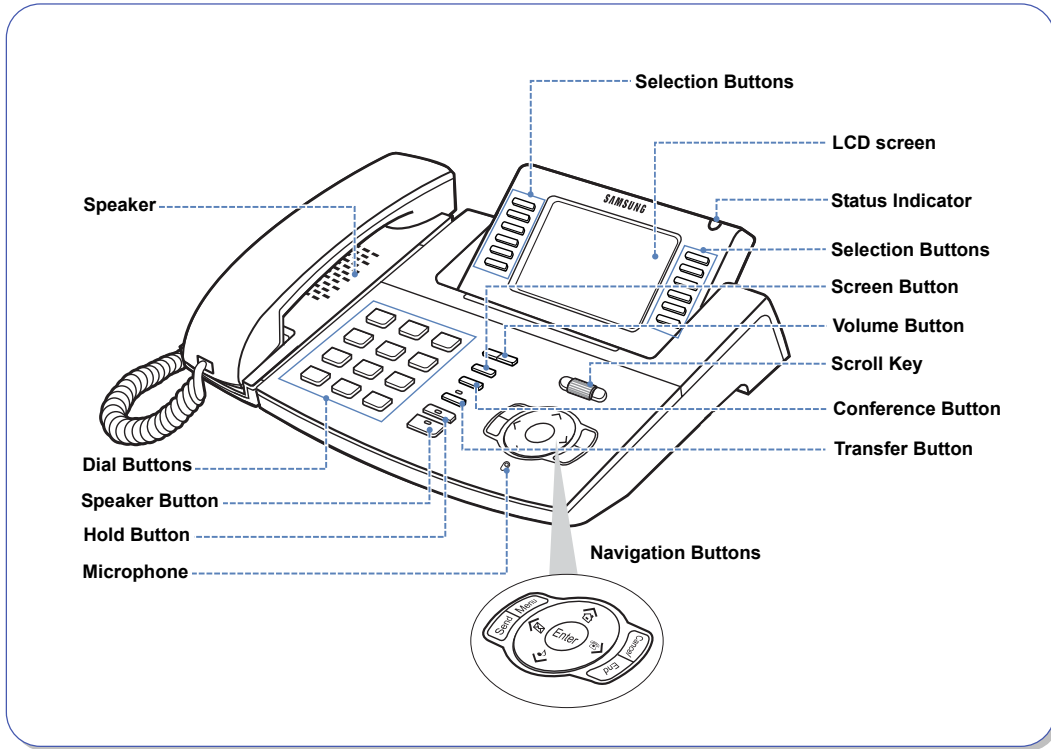

Connecting Lines to the Phone

- 1 Connect the handset to the handset connection port.
- 2 Connect the line cord to the phone line connection port.
- 3 To connect a recording device to the phone, connect the recording device connection port(REC) to your recorder.
 - The recording device jack can be connected to the recorder.
 - The recording device can record the phone conversation.
- 4 To use the Samsung Network SYNC program by connecting PC to the phone, connect one end of the data cable to the USB connection port of the phone and connect the other end to the USB port of PC.
 - The users who wish to use the Samsung Network SYNC program should refer to the User Guide.

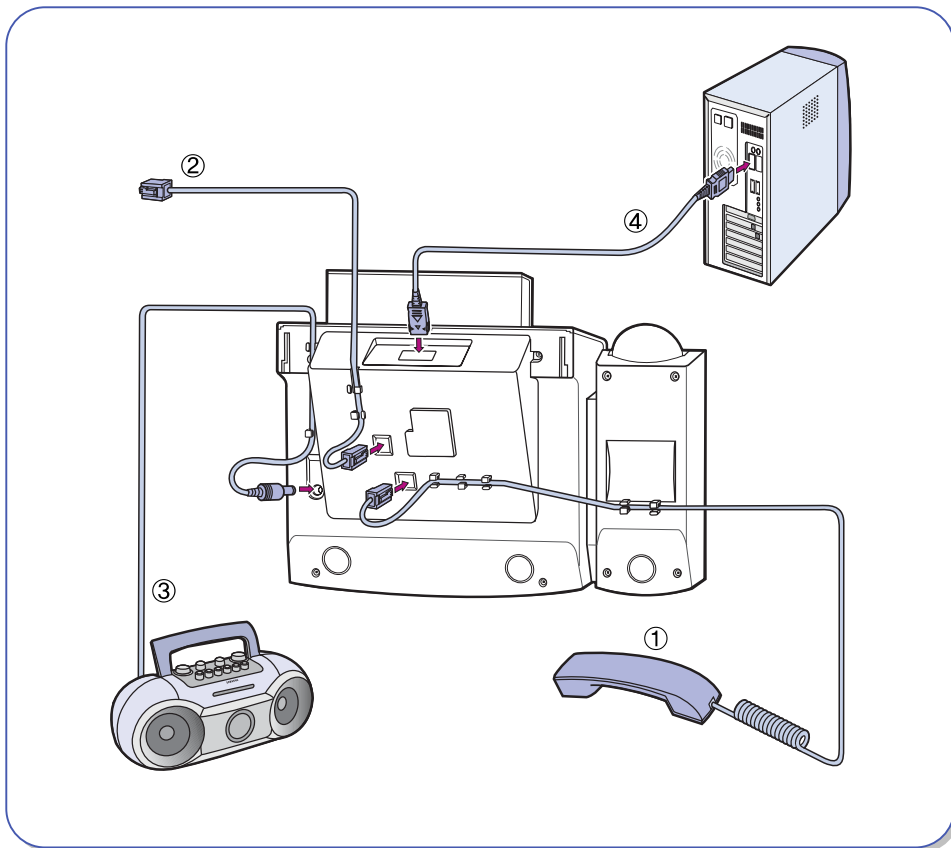

THINGS YOU SHOULD KNOW

Volume Adjustment

The [▼Volume▲] button is used for adjusting the volume of the handset, speaker, and ringer.

Adjusting Handset Volume

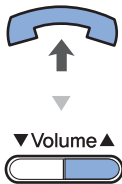

- 1** During a call using the **handset**, press the [Volume▲] button to increase the handset volume.



- 2** Press the [▼Volume] button to decrease the handset volume.

Adjusting Speaker Volume

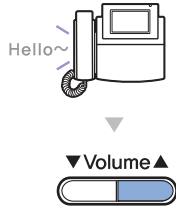

- 1 During a call using the **[Speaker]** button, press the **[Volume▲]** button to increase the speaker volume.



- 2 Press the **[▼Volume]** button to decrease the speaker volume.

Adjusting Ring Volume



- 1 To increase the ring volume, press the **[Volume▲]** button while the phone is ringing.



- 2 To decrease the ring volume, press the **[▼Volume]** button while the phone is ringing.

Entering Characters

Using the dial buttons and the navigation buttons of this phone, you can easily enter/edit, letters, numbers and special characters.

Selecting an Input Mode

When the input screen appears, press the [Menu] button until the required input mode is selected.

- Example of Character Input Screen

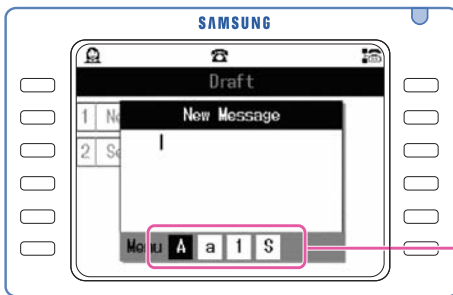

- A** : Alphabet Capital Letters Input Mode
- a** : Alphabet Lowercase Input Mode
- 1** : Numeric Input Mode
- S** : Special Characters Input Mode



NOTE

The default input mode is set to English.

Entering Letters of the Alphabet













- 1 Press the **[Menu]** button to select the alphabet input mode.

Use the  direction button to move a cursor.

- 2 Then, press the dial buttons to modify or insert the desired letters.

If the letter to enter is the same as the previous character, press the  direction button to move the cursor one space to the right or wait until the cursor moves automatically after a 3 second delay.

The location of alphabet letters on dial buttons is as follows.



Dial Button	Alphabet	Dial Button	Alphabet	Dial Button	Alphabet
			A B C		D E F
	G H I		J K L		M N O
	P Q R S		T U V		W X Y Z
	* / .				# @ -

- Press the button repetitively until the desired alphabet letter appears.

e.g.) Press  twice to enter K.

Press  three times to enter L.

- To enter another letter from the same button sequentially, enter the first letter, wait for about 3 seconds, and then press the button again.

- Press the  direction button to insert blank.
- To insert a blank between the entered characters, press the  direction buttons to move a cursor to a character that will be right next to the blank, and press the dial button [0] once.

- Press the **[Cancel]** button to delete any characters one by one.
Press the **[Cancel]** button for more than 2 seconds to delete all characters.

Entering Special Characters

- 1 Press the **[Menu]** button to select the special character input mode.
- 2 Then, the special characters that can be selected will be displayed on the lower part of the character input screen.

Press  direction button, to select the special characters and press

the **[Enter]** button. Or press  direction button to select another type of special characters.



NOTE

- Press the dial button [0] to insert a blank.
- Press the **[Cancel]** button to delete special characters one by one.
Press the **[Cancel]** button for more than 2 seconds to delete all characters.

Entering Numbers

Press the **[Menu]** button to select the numeric input mode and then press the dial button associated with the desired number.

Telephone Status Indicator

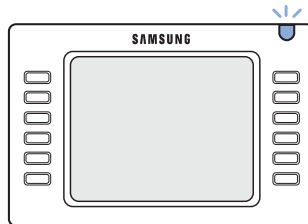

The status indicator turns on or off according to the telephone status.



Situation	Status Indicator
Busy	Steady red.
Station Ring	Flashing red.
Trunk Ring	Flashing blue.
Recall Ring	Flashing purple.
Message Camp On	Flashing red.
DND	Fast flashing red within 1 second interval.

Button LED

The **[Transfer]** button, **[Hold]** button, and **[Speaker]** button have a LED that turns on or off according to the phone status.

Button LED	LED Status	Function
Transfer 	Steady red	When 'Forward All Calls' is set or a Follow me has been set.
Hold 	Flashing red	When the phone is locked for any outgoing Trunk call.
	Steady red	When the entire phone is locked.
Speaker 	Steady red	When the phone is used as a speakerphone.

USING THE FEATURES

Making a Call

This function is used when you want to make a call to other stations or to make an external call.

Calling an Extension Number

This function is used when you want to make a call to other stations.



- 1** Pick up the handset and check for dial tone.

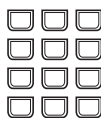

- 2** Dial the extension number of the other party.
 - Or, press the [Selection] button corresponding to the extension number in the programmable feature screen.



- 3** Press the [**Send**] button and ring tone will be heard.
 - If beep tones are heard, without ring tone, the station you called is set for a voice announcement or an automatic answer function. After the beep tones end, you can speak to the called party through their station speaker.



- 4** Begin speaking after the other party answers.

Calling an Outside number

This function is used when you want to make an external call.



1 Lift the handset and dial the trunk access code **[0]** and then dial the telephone number of outside party.

- Or, press the [Selection] button corresponding to the trunk line required in the programmable feature screen and dial the outside telephone number.



2 Press the **[Send]** button to make the call.



3 Begin speaking after the other party picks up the phone.

Using a Speakerphone

This function is used when you make a call with a speakerphone.

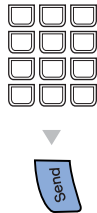

- 1 Dial the extension number(or the trunk access code followed by the telephone number) without lifting the handset and press **[Send]** button.



- 2 Listen to the speaker to hear a voice of the other party and speak through the microphone.
 - Listen to the speaker to hear a voice of the other party and speak through the microphone.



- 3 Finish the call, by pressing the **[Speaker]** button.

New Call

This function allows you to disconnect the existing call and make a new call on the same line.

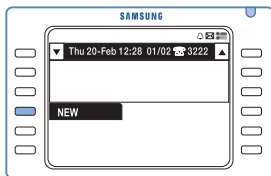

- 1 While on a call, press the [Selection] button corresponding to **[NEW]** menu displayed on the LCD screen. This will disconnect the current call and provide dial tone.



- 2 Dial an outside telephone number and press the **[Send]** button.

Redial

This function allows you to redial the last external number dialed.



- 1 When the phone is in standby mode, press the **[Screen]** button repeatedly until the Soft menu screen appears.

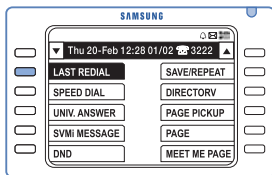

- 2 Press the [Selection] button corresponding to **[LAST REDIAL]** displayed on the Soft menu screen.



- 3 Begin speaking after the other party picks up the phone.

Saving the Telephone Number

You can save the current dialled external number for later use and redial the number.

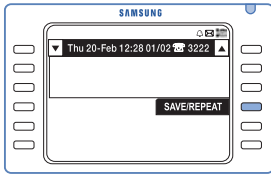

Press the [Selection] button for **[SAVE/REPEAT]** before hanging up the call, to save the phone number that has just been called.

Redialling the Saved Number

You can redial the saved number anytime.

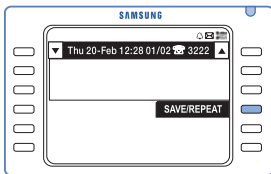

Press the [Selection] button for **[SAVE/REPEAT]** in the Soft Menu screen or press [1]▶[7].

- [1][7] is the function code for redialling the saved number.



NOTE

The saved number is stored in memory until you save another external number.

Answering a Call

This function is used when you want to answer an intercom call or outside call.

Using a Handset

This function is used when you answer a call with a handset.

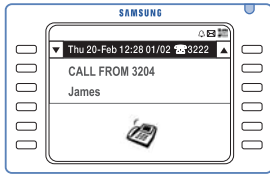

- 1** When the phone rings, a call receipt message will be displayed on the LCD screen.



- 2** Lift the handset and the ringing call will be automatically connected you.



- 3** Replace the handset after a conversation is over.

Using a Speakerphone

This function is used when you answer a call with a speakerphone.



- 1 Press the **[Send]** button without lifting the handset.



- 2 Listen to the speaker to hear a voice of the other party and speak through the microphone.

- You can switch from the speakerphone to the handset by lifting the handset.



- 3 Finish the call, by pressing the **[Speaker]** button.



NOTE

Press the **[▼Volume▲]** button while the phone is ringing to adjust the ringer volume.

Call Pickup

This function is used when you pickup a call that is ringing at another station.

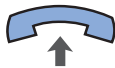

- 1 When you hear an unattended ringing station lift the handset.



- 2 Press **[6] ► [5]**, the function code for call pickup.



- 3 Dial the extension number of the ringing phone.

Features Used During a Call

These convenient functions may be used during a call.

Hold an Intercom Call

You can put the other party on hold if another call arrives or you wish to use both hands for another task and resume the call later.

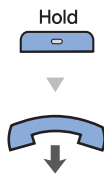

- 1 Press **[Hold]** button and replace the handset to put the current call on hold.

- The intercom call is placed into exclusive hold and cannot be retrieved at another station.

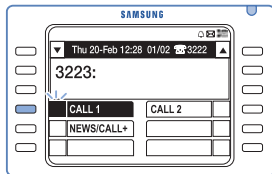

- 2 To call again, press the blinking **[CALL]** button in the programmable feature screen.

Hold an Outside Call

You can put the other party on hold if another call arrives or you wish to use both hands for another task and resume the call later.



1 Press **[Hold]** button and put the call on hold.



2 Press the **[Screen]** button until the Programmable Feature screen is displayed.

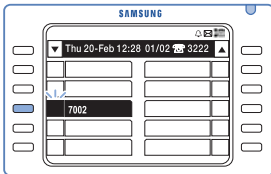

3 The number of the Trunk line call, which is on hold, blinks on the Programmable Feature screen. Press the **[Selection]** button of the blinking Trunk line number to resume the call.



4 Resume conversation.



NOTE

- If the **[Hold]** button is pressed once, you can reconnect to the party on hold from another phone.
- If the **[Hold]** button is pressed twice, you can reconnect to the party on hold only from the original phone.

Mute

During a call you can mute the handset transmitter or microphone while still listening to the other party.

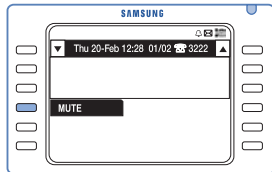

- 1 Press the [Selection] button for **[MUTE]** displayed on the screen.

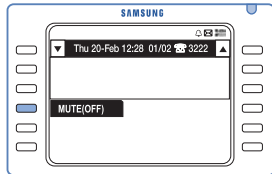

- 2 Press the [Selection] button for **[MUTE(OFF)]** to clear the Mute function.

Transferring a Call

While on an external call you can transfer the call to another internal or outside party.



1 Press **[Transfer]** button during the call.

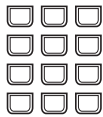

2 Dial the station/external number to which the call should be transferred.



3 Press the **[End]** button or replace the handset to immediately transfer the call or wait for the called party to answer and announce the transfer before disconnecting the call.



NOTE

- If the recipient of the transferred call does not answer or rejects the transfer, the call will recall to you.
- You can also press the **[Transfer]** button to reconnect to the outside caller.
- If the station you wish to transfer the call to is busy, you can camp-on the caller to the busy station by pressing the **[End]** button. The busy station will receive off hook ring to indicate a camp-on call.

Conference Calls

You can make a conference call of up to 5 parties including yourself. The OfficeServ system also.



- 1 Press **[Conference]** button while on a call.
You will hear conference tone.

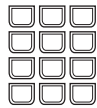

- 2 Dial the number of the internal or external party you wish to add to the conference, wait for them to answer and press **[Conference]** button again.



- 3 Dial the number of another internal or external party to be added to the conference or press the **[Conference]** button to begin the conference.
The conference connection status of all the numbers is displayed.



NOTE

If you press **[Transfer]** button and dial the conference function code [4][6], you can use the conference function to add additional parties.

APPLICATION MENUS

Navigation Buttons

Navigation buttons are provided for your convenience.

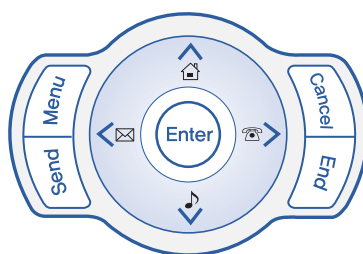

Menu Button

When the **[Menu]** button is pressed in the standby mode, the phones application menus are displayed as icons.



NOTE

If the **[End]** button or **[Speaker]** button is pressed in the application menu, the phone automatically exits the menus.

Send Button

- The phone is set to 'Enbloc' dialling mode as default. So, when you enter phone numbers, they can be reviewed before dialling. Press the **[Send]** button to dial the number.
- Answers incoming calls.
- Dials the most recently called number when pressed and held. If the **[Send]** button is pressed briefly in the standby mode, your recent calls are listed on the screen.

Enter button

The Enter button is used in the menu mode to select or save the corresponding item.

Direction button

These buttons are used when editing menu entries, or when moving between menu items.

① [^] button is used

- To move the cursor upward.
- To select the main menu.

② [>] button is used

- To select the Phonebook menu.
- To move the cursor to the right.

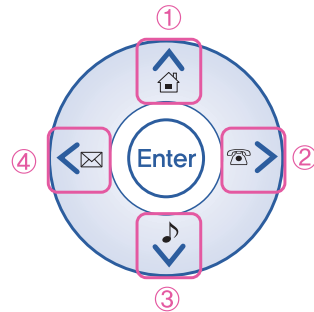

③ [v] button is used

- To select the Ring Type/Volume menu.
- To move the cursor downward.
- When moving to the lower menu item of the current menu.

④ [<] button is used

- To select the Text Message menu.
- To move the cursor to the left.

Cancel button

- Moves to the previous page of a menu.
- Deletes the entered letter or number.

End

- Disconnects the current call.
- Exits from the current mode to the idle screen.

Entering Application Menus

When the phone is in the standby mode, press the **[Menu]** button. The main application menu will appear on the LCD screen.

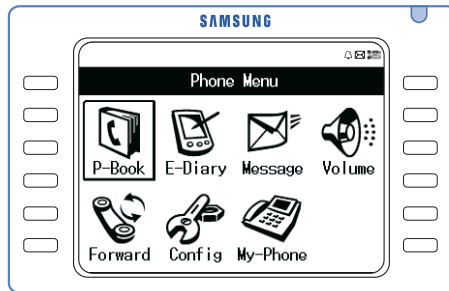

How to Select Menu

- Use the direction button to move to the desired application. Then, press the **[Enter]** button.
- Dial the corresponding number to the number of the required menu item.
(P-Book[1], E-Diary[2], Message[3], Volume[4], Forward[5], Config[6], My-Phone[7])
- Press the **[End]** button to exit the application menus.



NOTE

When there is a black mark at the bottom right of the LCD panel, you can press the **[Menu]** button for other functions.

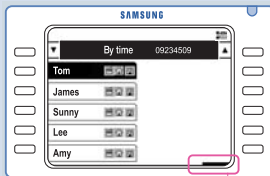

Click **[Menu]** button

Application Menus

The main menus and their sub menus are shown as follows.

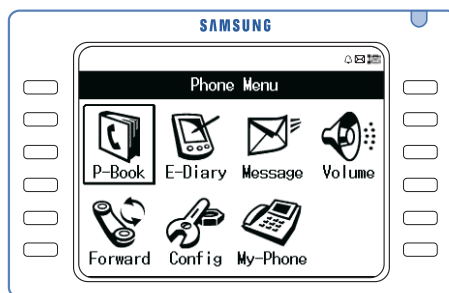

Main Menu	Sub Menu	Main Menu	Sub Menu
Phone Book	<ol style="list-style-type: none"> 1. Search 2. Outgoing Calls 3. Incoming Calls 4. New number 5. Edit Group 6. Delete all 	Call Forward	
E-diary	<ol style="list-style-type: none"> 1. Wakeup call 2. Alarm 3. Daily planner 4. Memo pad 5. Calculator 6. World Time 7. D-Day Plus 8. Unit Convert 	Configuration	<ol style="list-style-type: none"> 1. Password 2. Locked 3. Answering Mode 4. Boss Answering 5. LANGUAGE 6. CID Display 7. Absent Msg. 8. Internal Call 9. Dial Mode 0. Station On/Off
Text Message	<ol style="list-style-type: none"> 1. Received 2. Write & Sent 3. Draft 	My Phone	<ol style="list-style-type: none"> 1. Select BG 2. My Name 3. Status Info 4. Enbloc Timeout 5. News Color 6. Privacy Option 7. Config. Reset 8. Version Info
Ring Type/Volume	<ol style="list-style-type: none"> 1. Ring Type 2. Ringer 3. OffHook Ring 4. Handset 5. Speaker 6. BGM 7. Page 		

ANNEX

Troubleshooting

Possible problems and troubleshooting steps for your phone are described below. Check the troubleshooting steps before contacting your Authorised Samsung Reseller.

? **Dial tone is not heard when you lift the handset or press the [Speaker] button.**

- If the phone's dial mode is set to 'Enbloc', you will hear dial tone only after pressing the **[Send]** button. You should consult the System Administrator.
- Check if the handset and phone line are correctly connected to each port of the DS-5012L phone.(Refer to 'Connecting Lines to the Phone' section of 'Preparation' in this guide.)

? **Nothing appears on the LCD screen while the DS-5012L phone is being used.**

Check if the phone line is correctly connected to the port of the DS-5012L phone. (Refer to 'Connecting Lines to the Phone' section of 'Preparation' in this guide.)

? **The DS-5012L phone does not ring and volume is too low.**

Press the **[▼Volume▲]** button to adjust the volume. (Refer to 'Volume Adjustment' section of the 'Things You Should Know' section in this guide.)

? **Conversation quality is reduced due to noise and echo.**

If you are using the speakerphone, lift the handset and try speaking.

? Excessive echo is heard during a page announcement or with Auto Answer set.

If the phones are too close to each other, sound from one speaker might echo during a page or on auto answer call.

Keep a reasonable distance (about 1 m) between phones.

? An alarm does not ring at the programmed time.

- Check the current time is set on the DS-5012L phone correctly. If the current time setting needs to be changed, consult the System Administrator.
- Check if an alarm is set. You should consult the System Administrator.

? Caller IDs are not displayed on the LCD screen.

- Confirm with your System Administrator that the caller ID service is available from your Telephone Company.
- If the caller blocks the sending of their caller ID, the caller ID will not be displayed.
- If the caller makes a call from an area where the caller ID cannot be provided (e.g. international calls), the caller ID will not be displayed.
- If the caller makes a call from a public phone, the caller ID will not be displayed.
- If the caller ID received from the Telephone Company is corrupt, the caller ID will not be displayed.
- If the Telephone Company does not send a caller ID, the caller ID will not be displayed.

Product Specifications

The specifications and features of the DS-5012L digital phone are as follows.

Items	Specification
Model	DS-5012L
Weight(kg)	1.1
Size(mm)	266(width)×206(length)×122(height)
Operating Temperature(°C)	0 to 45
Operating Humidity(%)	10 to 90 non condensing
Number of the [Selection] buttons	12
Navigation Buttons	O
Speakerphone	Full Duplex mode
LCD	Graphic LCD(320×240 pixel)

● CLASS B(Digital device or Peripheral) ●

This equipment has been tested and found to comply with the limits for a Class B digital device, pursuant to International Standards EN55022, and EN61000, Part 15 of the FCC Rules and Australian Standard AS/NZS3548. These limits are designed to provide reasonable protection against harmful interference in a residential installation. This equipment generates, uses and can radiate radio frequency energy and, if not installed and used in accordance with the instructions, may cause harmful interference to radio communications. However, there is no guarantee that interference will not occur in a particular installation. If this equipment does cause harmful interference to radio or television reception, which can be determined by turning the equipment off and on, the user is encouraged to try to correct the interference by one or more of the following measures:

- Reorient or relocate the receiving antenna.
- Increase the separation between the equipment and receiver.
- Connect the equipment into an outlet on a circuit different from that to which the receiver is connected.
- Consult the dealer or experienced radio TV technician for help.

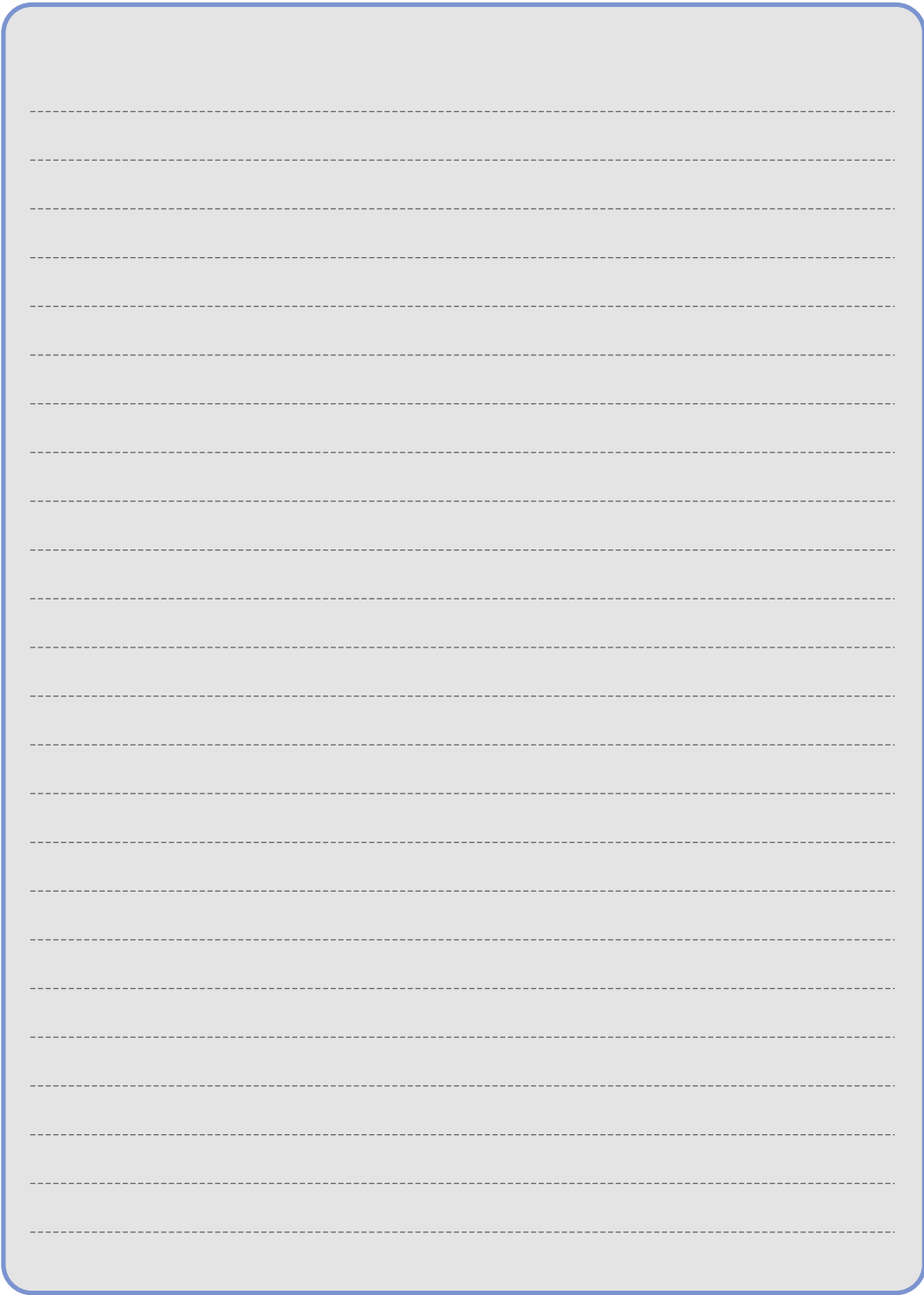

Information in this document is proprietary to
SAMSUNG Electronics Co., Ltd.

No information contained here may be copied, translated,
transcribed or duplicated by any form without the prior written
consent of SAMSUNG.

Information in this document is subject to change
without notice.



Enterprise IP Solutions
 **OfficeServ** Digital Phone **Quick Reference Guide**
DS-5012L



Part No. : GA68-00237A
Printed in Korea